

## Product Data Sheet

### VPPR28682NC – Deck Mounted Mixer Self Closing Tap

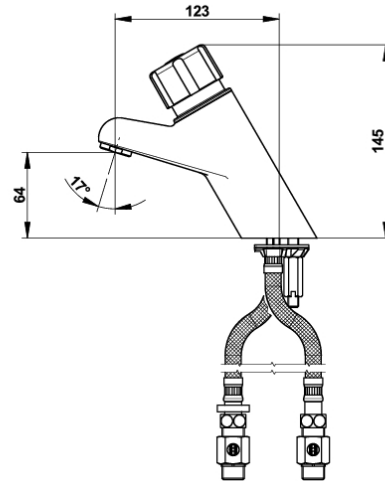

#### Working Pressure:

- ▶ 1 to 5 bar

#### Flow:

- ▶ 1.9 l/min (0.5 gpm) Spray with integrated flow limiter
- ▶ Anti water hammering design
- ▶ Vandalism proof and anti-clogging spout

#### Flow Time:

- ▶ 15 seconds ( $\pm 5$  seconds)

#### Hydraulic Supply:

- ▶ G 3/8" (12x17) on hose
- ▶ G 1/2" (15x21) on stop valve

#### Material & Colour Finish:

- ▶ Chrome plated push button

#### Thermal Resistance:

- ▶ Resistant to a temperature of 75°C for 30 minute thermal shocks

#### Security:

- ▶ Adjustable tamper-proof temperature limiter to prevent scalding
- ▶ Patented anti-blocking "S" system to prohibit permanent water flow from the tap

#### Supplied With:

- ▶ 2 filter gaskets
- ▶ 2 wras stop valves M G3/8 - F G1/2
- ▶ 2 PEX hoses with NF check valves and nuts F G3/8
- ▶ Fixing bracket
- ▶ 1 flange gasket
- ▶ 1 brass clamping nut
- ▶ 1 installation guide

#### Standards & Approvals:

- ▶ Acoustic class I
- ▶ Brass body in accordance with EN1982, EN12164, EN12165
- ▶ 200 hour neutral salt spray resistant (NSS) in accordance with ISO 9227
- ▶ WRAS certified : 2304309

